

# LLIGATS METÀL·LICS S.L.

<b>WIREHOOD TECHNICAL SHEET</b>		<b>Date:</b> 11.03.14	<b>Number:</b> 268
		<b>Customer:</b>	
Code: D-1000.0-00052-AT091DBG11R		Description: Galvanized wirehood with brilliant cap	
Code material customer:		Technical Specifications: D6/11 Ref.0.9 date 1-02-14	

RAW MATERIAL	Wire: Galvanized steel according EN10016-2 C9D	Cap: Electrolytic tinplate according EN 10203				
WIRE	0.97±0.03 Zinc coated >35gr/mm2	①Galvanized	②Galvanized	③Galvanized	④Galvanized	⑤Galvanized
WIREHOOD	Type: D	Belt shape: 2002-1	Body shape: 2000-1	Application: Bottle NHF 35-029		
BOX	Carton	Type: A without cover	Base: 562x473	Height: 180	Quantity per box/tray.: 3000	
STRIP	Guide: Carton	Length: 500	Wirehoods: 91	Length of guide strip: 510 ± 10		
PACKAGE	Non Return	Pallet: Industry G 1.150X980X120 mm	Quantity: 132.000	Weight: 745 Kg	Height: 2170 mm	
CAP	0.22±0.02 Tin coated 2.8gr/mm2 on both sides					

Cap Ref.: 00052		RAC signature	
PRINTING		CUSTOMER signature	
Process: 1			Inks:
Disc: 35Ø			
Notes:			

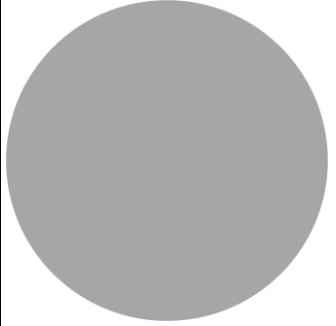
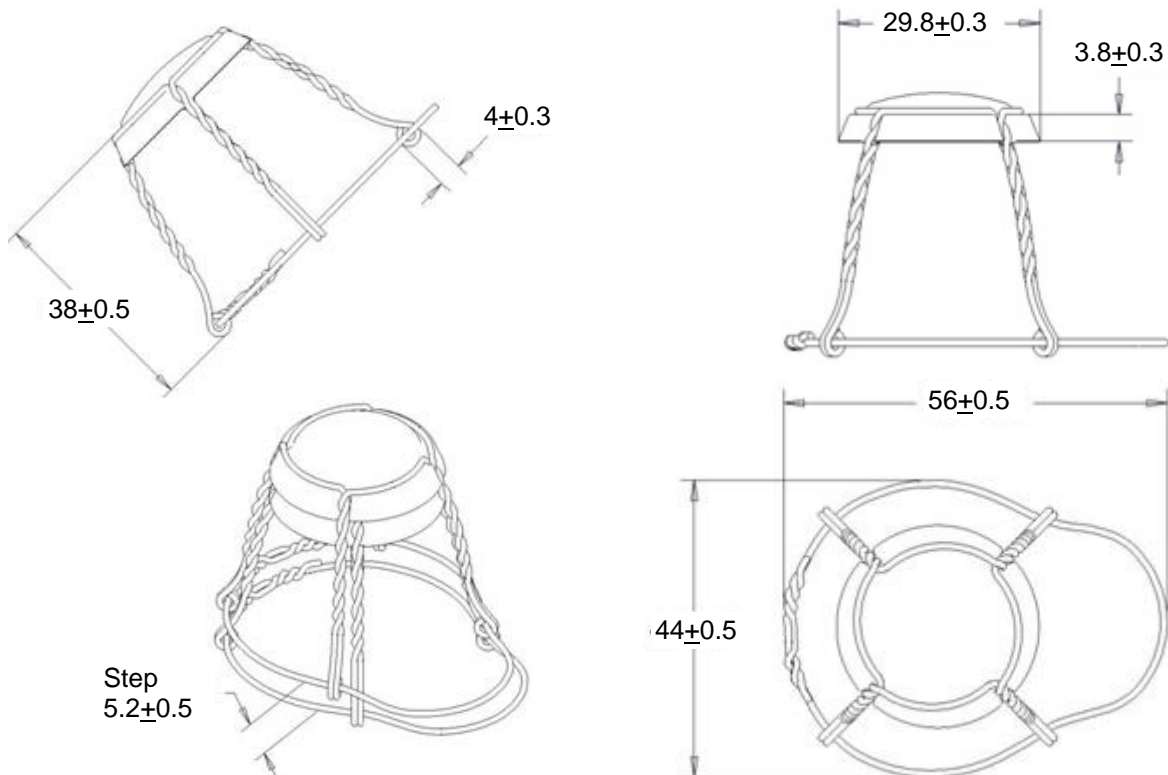

<a href="http://www.sabat.es">www.sabat.es</a>	Tel. 93 891 08 83	Fax 93 891 21 14	E-mail: <a href="mailto:sabat@sabat.es">sabat@sabat.es</a>
<b>This technical sheet determines de parameters of the referenced wirehoods. These parameters are more extended in the Technical Specifications mentioned above. Dimensions in mm.</b>			